



QM1002-0.5-18-X | 0.5 to 18 GHz RF Upconverter, Single (X=1) or Dual (X=2) Channel

Typical Applications

- Frequency Conversion
- Laboratory Test Equipment
- Digital Transmit Systems, Modulation
- Communication systems, SATCOM
- EW, ELINT, SIGINT
- Wideband systems
- Phased array antenna systems
- Radar systems



QM1002-0.5-18-2 with Option 100, 200, 1U 19" Rack-Mount



QM1002-0.5-18 in Optional Outdoor Unit Form-Factor

General Description

The QM1002-0.5-18-X Wideband Upconverter is a frequency agile RF Upconverter unit capable of producing output waveforms with frequencies centered between 1 and 18 GHz with 1 GHz of instantaneous bandwidth. The IF input frequency is typically centered at 1 GHz (750 to 1250 MHz), with an optional (OPT 200) third stage to further convert up from 50-550 MHz, to 50-90 MHz with OPT 201, or to 1-2 GHz with OPT 207.

QM1002 Series frequency converters now come standard with internally generated LOs (formerly Option 100). A switched LNA is included on the upconverter with Options 200, 201, and 207. An optional parallel TTL interface is provided on the back panel for fast tuning through a parallel DB-37 connector.

RF Output Frequency Range

QM1002-0.5-18-X 0.5 to 18 GHz

IF Input Frequency Range

Base Unit	750 to 1250 MHz
Option 200	50 to 550 MHz
Option 201	50 to 90 MHz
Option 207	1 to 2 GHz

Features

- Single (X=1) or Dual (X=2) channel options
- Base Option 100 provides internal LO generation with USB and TCP/IP control
- Up to 1 GHz instantaneous bandwidth
- Option for external LO tuning
- Independent (110) or common channel frequency control available on dual channel systems
- Frequency agile across entire tunable band

Form-Factor

- 1U 19" Rack module
- Optional weather-tight outdoor unit (11.81"x16.90"x4.76")



Quonset Microwave
www.quonsetmicrowave.com

QM1002-0.5-18-X **0.5-18 GHz Wideband RF** **Upconverter**

The QM1002-0.5-18-X is controlled via USB or TCP/IP and uses VISA control drivers with the USBTMC protocol, enabling seamless integration into Windows[®], Linux[®], and Macintosh[®] environments. A Windows[®] GUI is provided.

All QM1002 Series specifications are customizable upon request. Please contact sales@quonsetmicrowave.com for more information. Detailed performance specifications are also available upon request.



Quonset Microwave
www.quonsetmicrowave.com

QM1002-0.5-18-X
0.5-18 GHz Wideband RF
Upconverter

Electrical Specifications Base Unit without Option 200, 201, or 207 selected

Parameter	Min.	Typ.	Max.	Units
IF Input Center Frequency	750	1000	1250	MHz
RF Output Frequency Range	0.5		18	GHz
Instantaneous Usable Bandwidth		500		MHz
IF Ripple (+/- 250 MHz)		8	10	dB
Gain, 0.5-18 GHz	25		40	dB
Noise Figure (NF)		12	14	dB
Input P1dB, 0.5-18 GHz		-6		dBm
Output P1dB, 0.5-18 GHz	20	23	28	dBm
Phase Noise, 1 KHz Offset	-82	-78	-72	dBc/Hz
Phase Noise, 10 KHz Offset	-81	-80	-77	dBc/Hz
Phase Noise, 100 KHz Offset	-79	-77	-76	dBc/Hz
Phase Noise, 1 MHz Offset	-103	-106	-106	dBc/Hz
Phase Noise, 10 MHz Offset	-120	-120	-119	dBc/Hz
Harmonics (-30 dBm input)			-40	dBc
In-Band Spurious, +/- 250 MHz		-60	-50	dBc
Wideband Spurious, 0.5-18 GHz		-50		dBc
SFDR (Two-tone test)		50		dB

For price, delivery, and to place orders, please contact Quonset Microwave:
315 Commerce Park Road, North Kingstown, RI 02852 Phone: 401-295-0062



Quonset Microwave
www.quonsetmicrowave.com

QM1002-0.5-18-X
0.5-18 GHz Wideband RF
Upconverter

Electrical Specifications with Option 200 selected

Parameter	Min.	Typ.	Max.	Units
IF Input Center Frequency	50	300	550	MHz
RF Output Frequency Range	0.5		18	GHz
Instantaneous Usable Bandwidth		500		MHz
IF Ripple (+/- 250 MHz)		8	10	dB
Gain, 0.5-18 GHz, LNA In	25		40	dB
Gain, 0.5-18 GHz, LNA Out	10		25	dB
Noise Figure (NF), LNA In		12	14	dB
Noise Figure (NF), LNA Out	20	25	30	dB
Input P1dB, 0.5-18 GHz, LNA In		-6		dBm
Input P1dB, 0.5-18 GHz, LNA Out		5		dBm
Output P1dB, 0.5-18 GHz, LNA In	20	23	28	dBm
Output P1dB, 0.5-18 GHz, LNA Out	20	23	28	dBm
Phase Noise, 1 KHz Offset	-82	-78	-72	dBc/Hz
Phase Noise, 10 KHz Offset	-81	-80	-77	dBc/Hz
Phase Noise, 100 KHz Offset	-79	-77	-76	dBc/Hz
Phase Noise, 1 MHz Offset	-103	-106	-106	dBc/Hz
Phase Noise, 10 MHz Offset	-120	-120	-119	dBc/Hz
Harmonics (-30 dBm input)			-40	dBc
In-Band Spurious, +/- 250 MHz		-60	-50	dBc
Wideband Spurious, 0.5-18 GHz		-50		dBc
SFDR (Two-tone test)		50		dB

For price, delivery, and to place orders, please contact Quonset Microwave:
315 Commerce Park Road, North Kingstown, RI 02852 Phone: 401-295-0062



Electrical Specifications with Option 201 selected

Parameter	Min.	Typ.	Max.	Units
IF Input Center Frequency	50	70	90	MHz
RF Output Frequency Range	0.5		18	GHz
Instantaneous Usable Bandwidth		40		MHz
IF Ripple (+/- 250 MHz)		8	10	dB
Gain, 0.5-18 GHz, LNA In	25		40	dB
Gain, 0.5-18 GHz, LNA Out	10		25	dB
Noise Figure (NF), LNA In		12	14	dB
Noise Figure (NF), LNA Out	20	25	30	dB
Input P1dB, 0.5-18 GHz, LNA In		-6		dBm
Input P1dB, 0.5-18 GHz, LNA Out		5		dBm
Output P1dB, 0.5-18 GHz, LNA In	20	23	28	dBm
Output P1dB, 0.5-18 GHz, LNA Out	20	23	28	dBm
Phase Noise, 1 KHz Offset	-82	-78	-72	dBc/Hz
Phase Noise, 10 KHz Offset	-81	-80	-77	dBc/Hz
Phase Noise, 100 KHz Offset	-79	-77	-76	dBc/Hz
Phase Noise, 1 MHz Offset	-103	-106	-106	dBc/Hz
Phase Noise, 10 MHz Offset	-120	-120	-119	dBc/Hz
Harmonics (-30 dBm input)			-40	dBc
In-Band Spurious, +/- 250 MHz		-60	-50	dBc
Wideband Spurious, 0.5-18 GHz		-50		dBc
SFDR (Two-tone test)		50		dB



Electrical Specifications with Option 207 selected

Parameter	Min.	Typ.	Max.	Units
IF Input Center Frequency	1	1.5	2	GHz
RF Output Frequency Range	0.5		18	GHz
Instantaneous Usable Bandwidth		1		GHz
IF Ripple (+/- 250 MHz)		8	10	dB
Gain, 0.5-18 GHz, LNA In	25		40	dB
Gain, 0.5-18 GHz, LNA Out	10		25	dB
Noise Figure (NF), LNA In		12	14	dB
Noise Figure (NF), LNA Out	20	25	30	dB
Input P1dB, 0.5-18 GHz, LNA In		-6		dBm
Input P1dB, 0.5-18 GHz, LNA Out		5		dBm
Output P1dB, 0.5-18 GHz, LNA In	20	23	28	dBm
Output P1dB, 0.5-18 GHz, LNA Out	20	23	28	dBm
Phase Noise, 1 KHz Offset	-82	-78	-72	dBc/Hz
Phase Noise, 10 KHz Offset	-81	-80	-77	dBc/Hz
Phase Noise, 100 KHz Offset	-79	-77	-76	dBc/Hz
Phase Noise, 1 MHz Offset	-103	-106	-106	dBc/Hz
Phase Noise, 10 MHz Offset	-120	-120	-119	dBc/Hz
Harmonics (-30 dBm input)			-40	dBc
In-Band Spurious, +/- 250 MHz		-60	-50	dBc
Wideband Spurious, 0.5-18 GHz		-50		dBc
SFDR (Two-tone test)		50		dB



Quonset Microwave
www.quonsetmicrowave.com

QM1002-0.5-18-X
0.5-18 GHz Wideband RF
Upconverter

Common Specifications

Parameter	Min.	Typ.	Max.	Units
Operating Voltage		+15		VDC
Current Draw			5	Amps
Tune Frequency Step Size				
Integer Mode		400		MHz
Fractional Mode		100		KHz
LO1 Input Frequency Range	21.5		39	GHz
LO1 Input Power		0		dBm
External Reference Input		10		MHz
External Reference Output		10		MHz

For price, delivery, and to place orders, please contact Quonset Microwave:
315 Commerce Park Road, North Kingstown, RI 02852 Phone: 401-295-0062



Option 200/201/207 Discussion for Upconversion Channels

QM1002 series frequency converter units are offered with an optional 50-550 MHz intermediate frequency range (Option 200) or an optional 50-90 MHz IF (Option 201). For applications utilizing a digital waveform generator, we recognize that DACs operating in the first Nyquist zone generally have output power levels approaching 0 dBm. Other applications for upconversion would utilize a lower-level analog input. With this in mind, we have included a switched LNA along with Options 200, 201, and 207.

Options Overview

To provide flexibility for system integration, the QM1002-0.5-18-X series of downconverters has multiple configuration options that pertain to three categories – (1) Local Oscillator (LO) generation, (2) Independent vs. common channel control for dual channel systems, (3) IF frequency modifications. An internal common LO (Option 100) is not included with the Base system.

To select options related to LO generation and independent/common channel control, the following option codes are provided.

Option Code	Description
100 (Base System)	With the Base System (Option 100), a common LO1 and LO2 are included in the unit. Both a USB type-A connector and an RJ-45 (TCP/IP) connector are added to the back panel for LO control. In dual channel systems with the Base Option Code 100 selected, LOs are common, meaning both channels (up- and downconversion) are always tuned to the same frequency.
110	When Option 110 is specified, separate independent LOs are included for the upconverter channels if two channels are included.
200	The IF input is changed to 50-550 MHz.
201	The IF input is changed to 50-90 MHz.
207	The IF input is changed to 1-2 GHz.



QM1002 Series System Block Diagrams

For the Base System (**Option 100**), LO1 and LO2 frequencies are generated internally. The LOs are PLL based and require a reference clock and digital control. Figure 1 depicts the system elements for the Base System (Option 100) with internal LOs. The LOs are controlled digitally via a microcontroller, which interfaces to a PC through USB or TCP/IP. The microcontroller outputs basic status messages on a 32-character Liquid Crystal Display (LCD) mounted on the faceplate of the unit. An internal low phase noise 10 MHz reference clock is phase-locked to all of the internal the LOs, with a BNC-F connector providing the option for LOs to lock to a user-provided external reference of 10 MHz. A second BNC-F connector outputs a 10 MHz reference used by the LOs for daisy chaining multiple pieces of equipment. Switching between the internal and external LO reference clocks is controlled by the microcontroller and a reference selector switch. The LO1 signal may be provided externally, and the selection between internal and external LO1 is provided by a back-panel switch. A DB-37 connector is provided on the back panel for optional fast-tuning that is controlled by an external TTL signal.

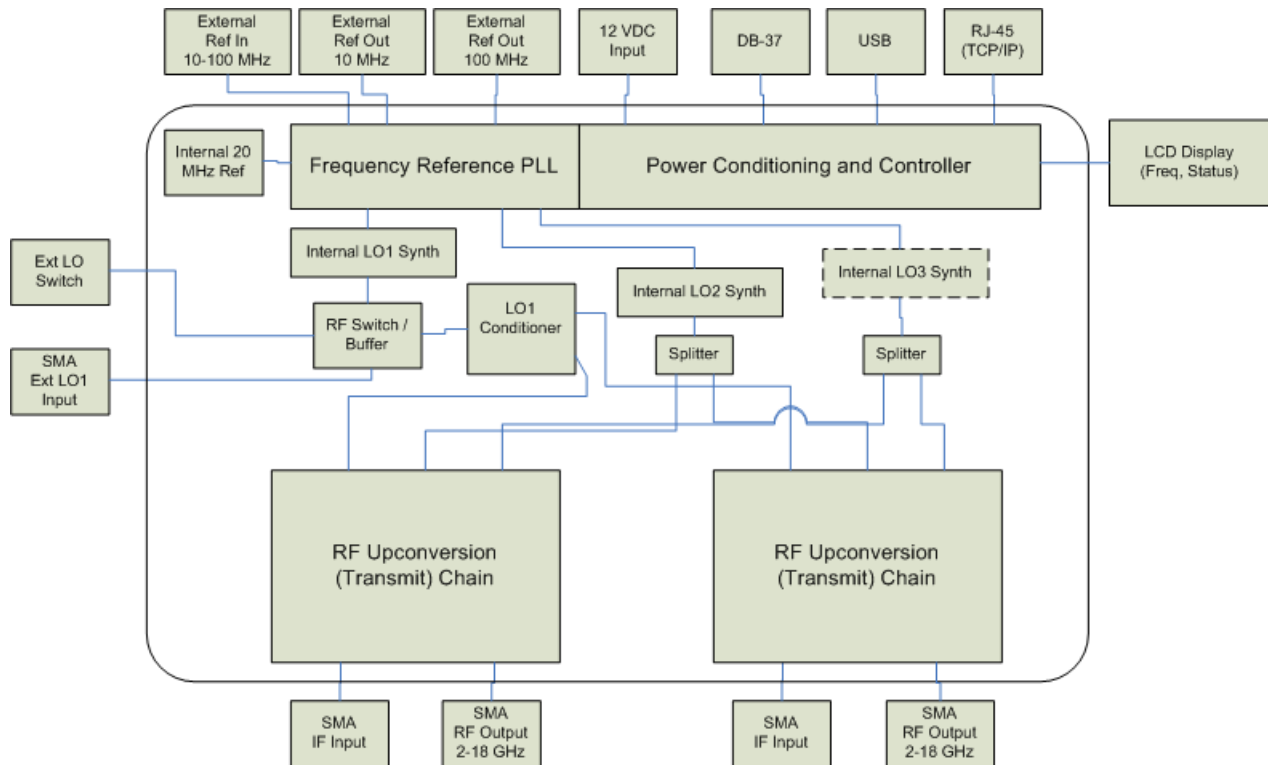

Figure 1. QM1002-0.5-18 block diagram for the Base System (Option 100) with optional third LO for optional third conversion stage (Options 200 or 201) shown in dashed line.

RF Signal Chain

QM1002 Series Wideband RF Upconverters use a dual stage conversion architecture to convert IF frequencies from a 1 GHz center-frequency IF (or 300 MHz with Option 200, 70 MHz with Option 201, and 1.5 GHz with Option 207) to RF. For details on the RF conversion signal chain, please contact sales@quonsetmicrowave.com.



In order to control the RF transmit/receive frequency, the internal LO1 synthesizer is tuned using either the provided Windows GUI or using VISA interface commands. Optionally, an external LO1 signal may be provided between 21.5 and 39 GHz.

Using the internal LOs, the LO1 frequency calculation is performed internally, and the user need only digitally choose their desired transmit/receive frequency. Otherwise, the LO1 input frequency can be calculated using the desired RF tune frequency with equation (1).

$$LO1 = (RF_{tune} + 21) \quad (1)$$

Option 200/201 RF Chain Modifications

Option 200 moves the IF from 750-1250 MHz down to 50-550 MHz, to 50-90 MHz for Option 201, and to 1-2 GHz for Option 207. This modification requires a third frequency conversion stage which converts the 1 GHz output IF to an IF output frequency centered at 300 MHz (Option 200) or 70 MHz (Option 201). As with all QM1002 series upconverter units, knowledge of the LO input frequencies and frequency plan calculation is only necessary if user-generated external LOs are required.

Controlling QM1002 Upconverters with Internal LOs (Option 100)

QM1002 Upconverters with internal LOs have been designed to be VISA and USBTMC compliant. Any PC and operating system with Virtual Instrument Software Architecture (VISA) drivers installed should be able to communicate with QM1002 units. VISA drivers are provided by many Test and Measurement companies, including Agilent Technologies, National Instruments, and Tektronix. USB and TCP/IP communication and command structure is discussed in detail in the frequency conversion programming manual. A lightweight GUI, supported in Windows®, will be provided for units with internal LOs, providing control of all commonly used commands.

Interface Connections

The necessary front and back panel input/output connections on a QM1002 Series frequency converter are summarized in Table 1. The front-panel connections are shown in Figure 2 while the rear-panel connections are shown in Figure 3. Interface connections for the optional Outdoor Unit are similar.



Figure 2. Front panel connections to QM1002-0.5-18.

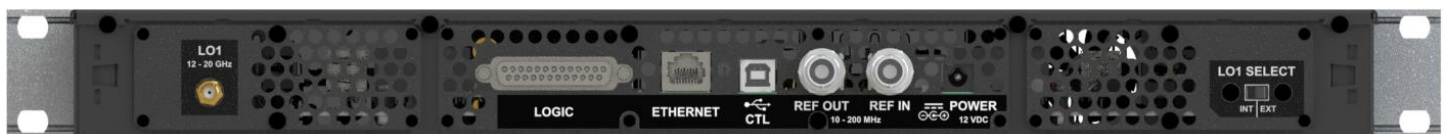

Figure 3. Rear-panel connections to QM1002-0.5-18.



Table 1. Input and output connections for QM1002-0.5-18-X (19" Rack Form-Factor)

Parameter	Connector Style	Type	Location
Channel 1 IF Input	SMA	Female	Front Panel
Channel 1 RF Output	SMA	Female	Front Panel
Channel 2 IF Input	SMA	Female	Front Panel
Channel 2 RF Output	SMA	Female	Front Panel
Reference Input (10 MHz)	BNC	Female	Rear Panel
Reference Output (10 MHz)	BNC	Female	Rear Panel
LO1 Input (21-39.5 GHz)	2.92 mm	Female	Rear Panel
USB	μ-B	Female	Rear Panel
Ethernet	RJ-45	Female	Rear Panel
Power Jack	2.1 mm Barrel	Male	Rear Panel
TTL Input (Frequency Tuning, Attenuation Control, Lock Status)	DB-37 (Formerly DB-25)	Female	Rear Panel

Power Interface

The QM1002 Upconverter requires a DC input voltage of 15V applied at the 5.5mm power jack (2.5mm barrel) on the back panel of the instrument. An AC-DC power adapter is supplied with the unit.

Absolute Maximums

Operating Temperature	+40 °C
RF Input Power	+2 dBm



ELECTROSTATIC SENSITIVE DEVICE
OBSERVE HANDLING PRECAUTIONS

Ordering Information

QM1002-0.5-18-X- [Options]-[ODU]

where

X= 1, 2 (# of Channels)

Options= 100, 110, 200, 201, 400, etc.

ODU= Optional Outdoor Unit Form-Factor